

Name \_\_\_\_\_

# Perimeter

**Perimeter** is the distance around a shape. You can use grid paper to count the number of units around the outside of a rectangle to find its perimeter.

**How many feet of ribbon are needed to go around the bulletin board?**

**Step 1** On grid paper, draw a rectangle that has a length of **5** units and a width of **3** units.

**Step 2** Find the length of each side of the rectangle. Mark each unit of length as you count.

**Step 3** Add the side lengths.  $5 + 3 + 5 + 3 = 16$

The perimeter is 16 feet.

So, 16 feet of ribbon are needed to go around the bulletin board.

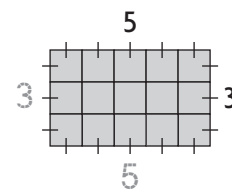
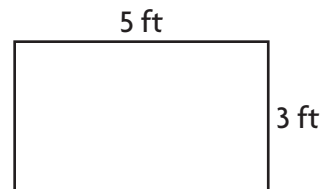

1. What is the perimeter of this square?

\_\_\_ + \_\_\_ + \_\_\_ + \_\_\_ = \_\_\_ centimeters

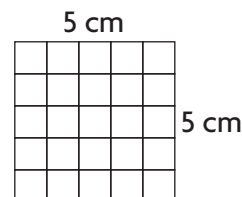

Find the perimeter of the rectangle or square.

2.

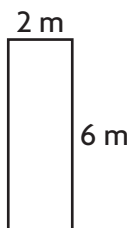

\_\_\_\_\_ meters

3.

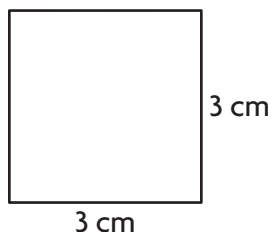

\_\_\_\_\_ centimeters

4.

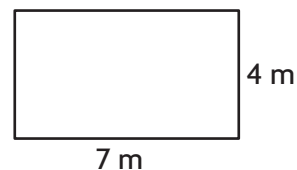

\_\_\_\_\_ meters

Name \_\_\_\_\_

# Area

**Area** is the number of **square units** needed to cover a flat surface.

Find the area of the rectangle at the right.

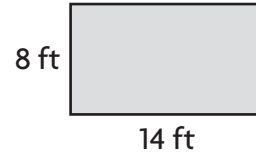

You can use the formula **Area = base × height**.

**Step 1** Identify one side as the base.

The base is 14 feet.

**Step 2** Identify a perpendicular side as the height.

The height is 8 feet.

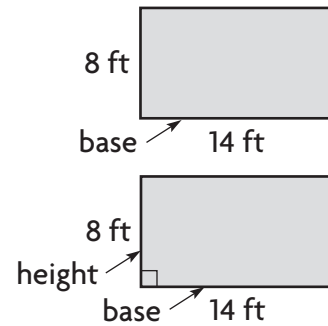

**Step 3** Use the formula to find the area.

$$\begin{aligned} \text{Area} &= \text{base} \times \text{height} \\ &= 14 \times 8 \\ &= 112 \end{aligned}$$

So, the area of the rectangle is **112** square feet.

Find the area of the rectangle or square.

1.

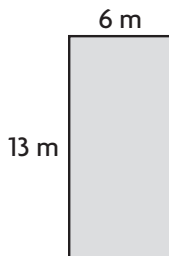

2.

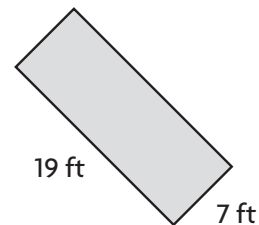

3.

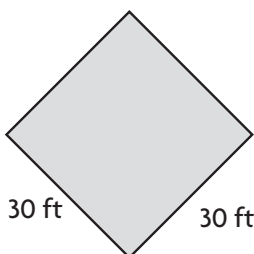

4.

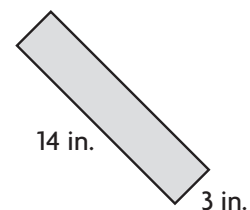

Name \_\_\_\_\_

# Area of Combined Rectangles

Find the area of the combined rectangles.

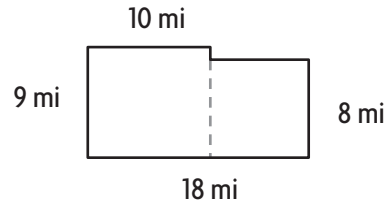

**Step 1** First, find the area of each section of the shape.

LEFT

$$\begin{aligned} A &= b \times h \\ &= 10 \times 9 \\ &= 90 \end{aligned}$$

RIGHT

$$\begin{aligned} A &= b \times h \\ &= 8 \times 8 \\ &= 64 \end{aligned}$$

**Think:**  $18 - 10 = 8$

**Step 2** Add the two areas.

$$90 + 64 = 154$$

So, the total area is 154 square miles.

Find the area of the combined rectangles.

1.

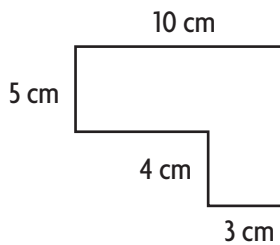

2.

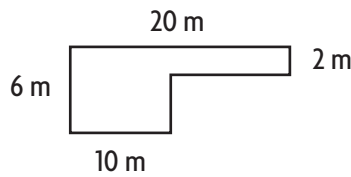

3.

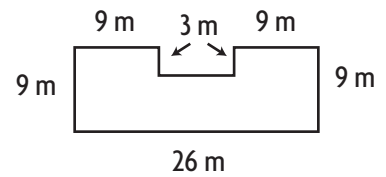

4.

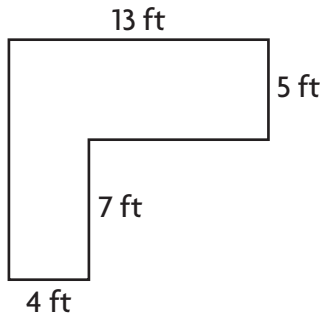

5.

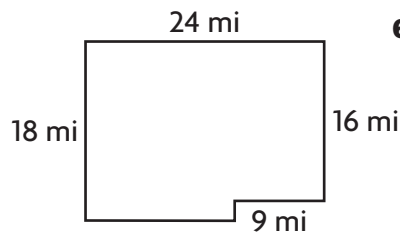

6.

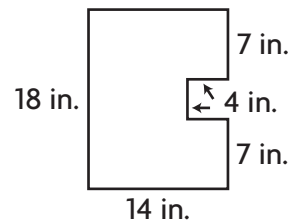

Name \_\_\_\_\_

# Find Unknown Measures

Fred has 30 yards of fencing to enclose a rectangular vegetable garden. He wants it to be 6 yards wide. How long will his vegetable garden be?

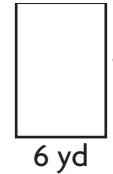

**Step 1** Decide whether this problem involves area or perimeter.

**Think:** The fencing goes *around the outside* of the garden. This is a measure of perimeter.

**Step 2** Use a formula for perimeter. The width is 6. The perimeter is 30. The length is unknown.

$$P = (2 \times l) + (2 \times w)$$

$$30 = (2 \times l) + (2 \times 6)$$

$$30 = 2 \times l + 12$$

**Step 3** Find the value of  $l$ .

$$18 = 2 \times l, \text{ so the value of } l \text{ is } 9.$$

The length of Fred's garden will be 9 yards.

Carol has 120 square inches of wood. The piece of wood is rectangular and has a height of 10 inches. How long is the base?

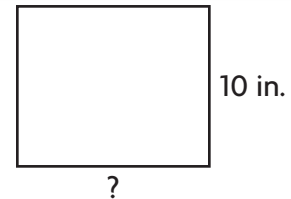

**Step 1** Decide whether this problem involves area or perimeter.

**Think:** *Square inches* is a measure of area.

**Step 2** Use a formula for area. The height is 10. The area is 120. The length is unknown.

$$A = b \times h$$

$$120 = b \times 10$$

**Step 3** Find the value of  $b$ .

Since  $120 = 12 \times 10$ , the value of  $b$  is 12.

The base of Carol's piece of wood is 12 inches.

## Find the unknown measure.

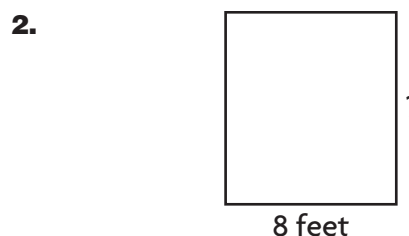
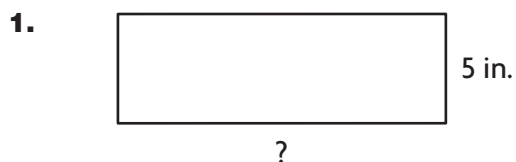

Perimeter = 40 inches

Area = 72 square feet

width = \_\_\_\_\_

height = \_\_\_\_\_

Name \_\_\_\_\_

# Problem Solving • Find the Area

Use the strategy *solve a simpler problem*.

Marilyn is going to paint a wall in her bedroom. The wall is 15 feet long and 8 feet tall. The window takes up an area 6 feet long and 4 feet high. How many square feet of the wall will Marilyn have to paint?

Read the Problem	Solve the Problem
<p><b>What do I need to find?</b></p> <p>I need to find how many <u>square feet of the wall</u> Marilyn will paint.</p>	<p>First, find the area of the wall.</p> $A = b \times h$ $= 15 \times 8$ $= 120 \text{ square feet}$
<p><b>What information do I need to use?</b></p> <p>The paint will cover the wall. The paint will not cover the <u>window</u>. The base of the wall is 15 feet and the height is <u>8 feet</u>. The base of the window is 6 feet and the height is <u>4 feet</u>.</p>	<p>Next, find the area of the window.</p> $A = b \times h$ $= 6 \times 4$ $= 24 \text{ square feet}$ <p>Last, subtract the area of the window from the area of the wall.</p>
<p><b>How will I use the information?</b></p> <p>I can solve simpler problems. Find the area of the <u>wall</u>. Then, find the area of the window. Last, <u>subtract</u> the area of the <u>window</u> from the area of the wall.</p>	$\begin{array}{r} 120 \\ - 24 \\ \hline 96 \end{array}$ <p><u>96</u> square feet</p> <p>So, Marilyn will paint <u>96 square feet</u> of her bedroom wall.</p>

- Ned wants to wallpaper the wall of his bedroom that has the door. The wall is 14 feet wide and 9 feet high. The door is 3 feet wide and 7 feet high. How many square feet of wallpaper will Ned need for the wall?

\_\_\_\_\_

- Nicole has a rectangular canvas that is 12 inches long and 10 inches wide. She paints a blue square in the center of the canvas. The square is 3 inches on each side. How much of the canvas is NOT painted blue?

\_\_\_\_\_